

LHX

Underground Loader



LHX125

Underground Loader

FEATURES

- Heavy duty frame construction providing a stable and reliable platform
- Dependable and proven power train components from leading suppliers
- Four-wheel drive, articulated steer carrier.
- Side mounted operator suspension seat with seat belts

ENGINE

- Deutz D914L04 @ 73HP (54kw) @ 2300RPM
- Air cooled engine (Tier 4i compliant)

TRANSMISSION

- Dana C271 series torque convertor with remote mounted Dana RT2000 series 3 speed power shift transmission

AXLES

- Dana 163 series

TIRES

- 10:00 x 20 solids

ELECTRICAL

- 24 volt electrical system
- LED light package

HYDRAULIC

- Pressure compensated, load sense piston pump
- Pilot operated joy stick controls

EQUIPMENT

BUILT TO PERFORM



www.waldenequipment.ca

LHX

Underground Loader



LHX125

Underground Loader

BUCKET CAPACITY

•1.25 yd³ (.96 m³)

TANK CAPACITIES

- Fuel – 42 usg (159 L)
- Oil – 42 usg (159 L)

BRAKES

- Service brakes are hydraulic applied, enclosed wet multi-disk brakes
- Park and Emergency brake is spring applied hydraulic released dry disk brake on front axle out put

AVAILABLE OPTIONS

- Ansul four nozzle fire suppression and fire extinguisher
- Lincoln auto lube system
- Wheel chocks and brackets
- FOPS/ROPS canopy
- Remote control

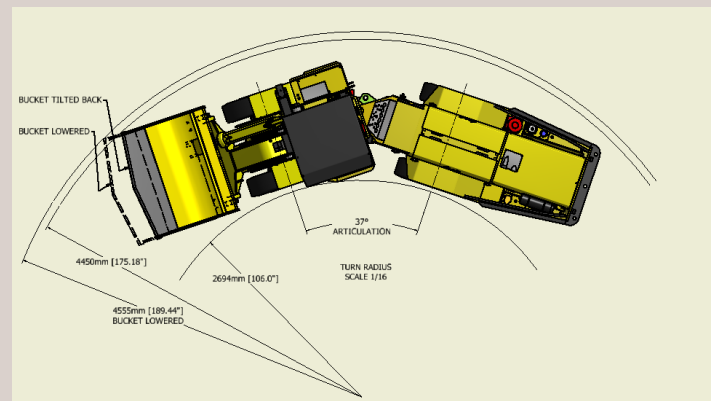
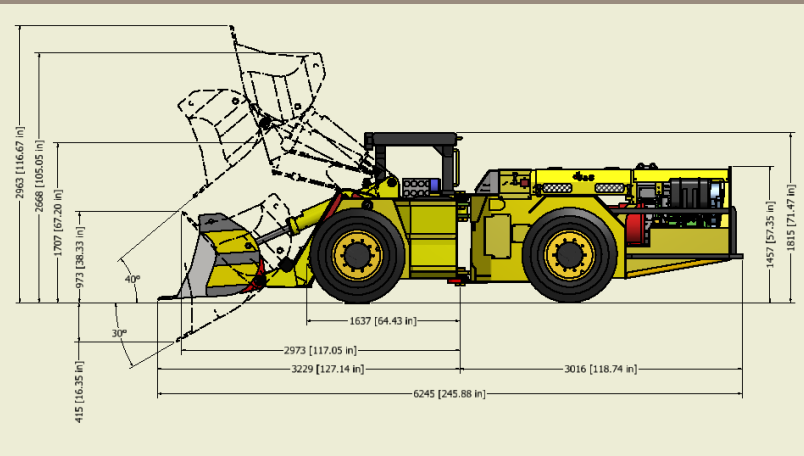
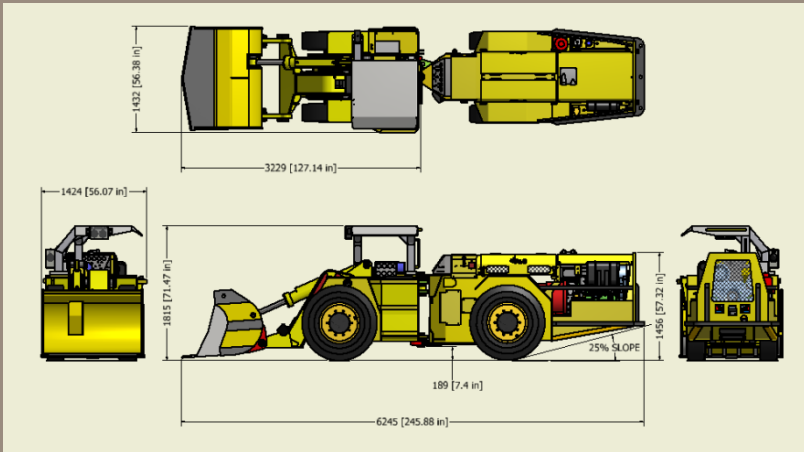

EQUIPMENT
**BUILT TO
PERFORM**



www.waldenequipment.ca